

"X": Pos. für SNAP IN

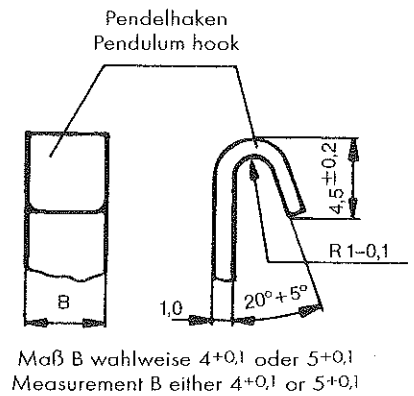
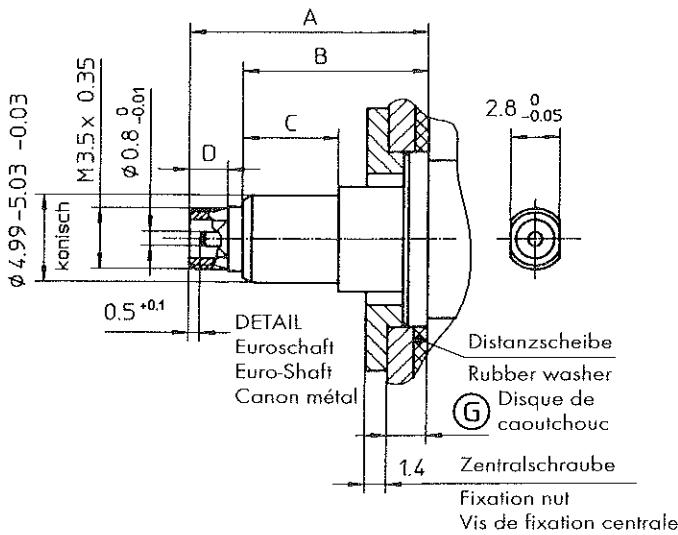
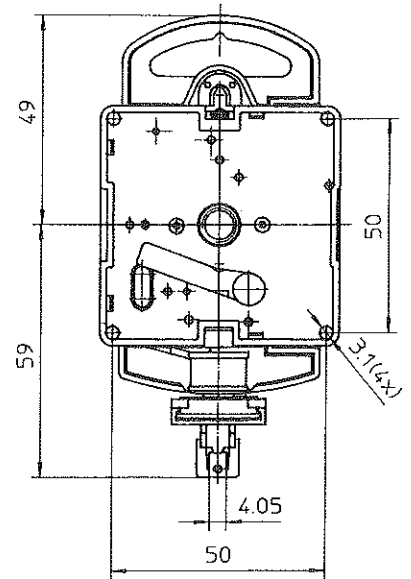

Maß B wahlweise 4+0,1 oder 5+0,1
 Measurement B either 4+0,1 or 5+0,1

Type	Detail	Abmessungen / Dimensions / Dimensions							
		A	B	C	D	\varnothing	\varnothing	\varnothing	G max.
817 053	Euroshaft	11,0	7,8	5,5	2,2	4,99-5,03-0,03	M3,5x0,35	0,8-0,01	4,0
817 055	Euro-Shaft	16,2	13,0	5,5	2,2	4,99-5,03-0,03	M3,5x0,35	0,8-0,01	9,2
817 056	Canon métal	20,1	16,9	5,5	2,2	4,99-5,03-0,03	M3,5x0,35	0,8-0,01	13,1

Zubehör / Accessory / Accessoire:

Zeigermutter Hand nut Ecrou aiguille			
Teile-Nr. Part no. Pièce no.	ø x s	Oberfläche / Surface / Surface	Typ
582 014	6 x 1,5	MS/brass/laiton	offen/open/ouvert
582 015	6 x 1,5	vernickelt/nickel plated/nickelé	offen/open/ouvert
582 016	6 x 1,5	schwarz/black/noir	offen/open/ouvert
582 019	6 x 1,5	MS/brass/laiton	geschlossen/shut/fermé
582 020	6 x 1,5	vernickelt/nickel plated/nickelé	geschlossen/shut/fermé
582 021	6 x 1,5	schwarz/black/noir	geschlossen/shut/fermé

Distanzscheibe Rubber washer Disque de caoutchouc	
Teile-Nr. Part no. Pièce no.	ø x s
580 075	30 x 2
580 076	30 x 1
580 077	30 x 0,5
580 520	30 x 3

Zentralschraube Fixation nut Vis de fixation centrale				
Teile-Nr. Part no. Pièce no.	Form Forme	Maß Dimension Longueur L-0,2	Oberfläche/ Surface/Surface	
			MS	Ni
581 374		5,2	X	
581 375		5,2		X
581 582		7,0	X	
581 583		7,0		X
581 376		9,0	X	
581 377		9,0		X
581 584		11,0	X	
581 585		11,0		X
581 586		13,0	X	
581 587		13,0		X
581 378		16,0	X	
581 379		16,0		X
581 964		21,0	X	
581 965		21,0		X